

MA1	MÓDULO DE ACCIÓN N°1
MA2	MÓDULO DE ACCIÓN N°2
MA3	MÓDULO DE ACCIÓN N°3
MA4	MÓDULO DE ACCIÓN N°4
MT5	MÓDULO DE TRANSICIÓN N°5
MT6	MÓDULO DE TRANSICIÓN N°6
MT7	MÓDULO DE TRANSICIÓN N°7

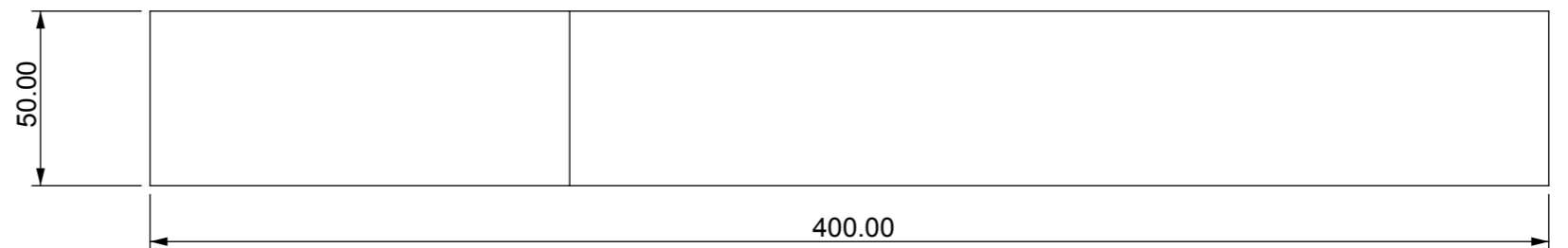

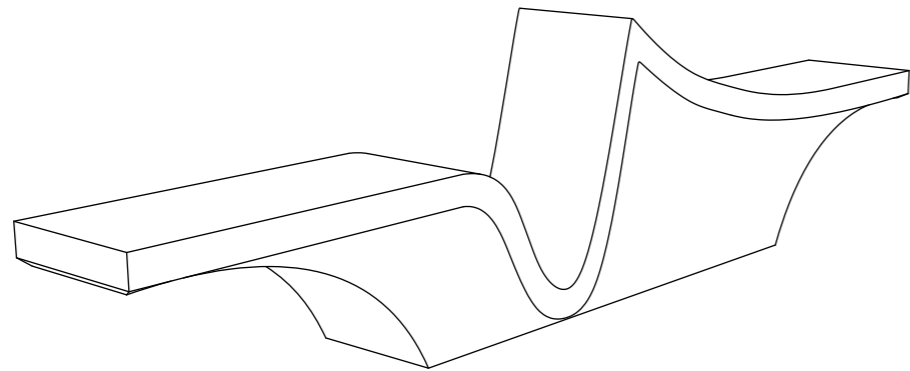

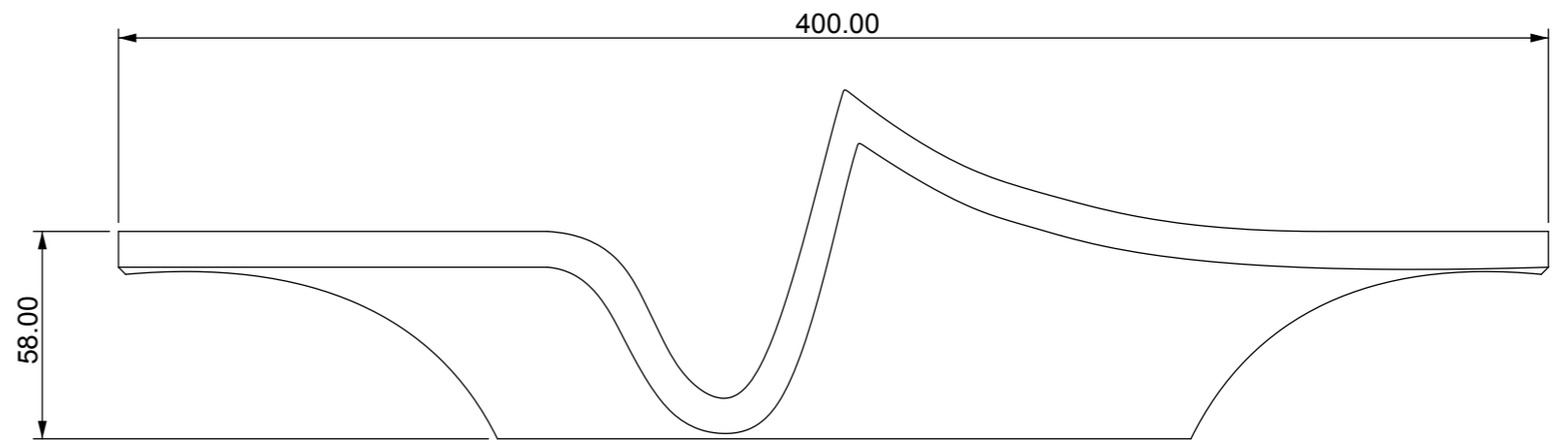

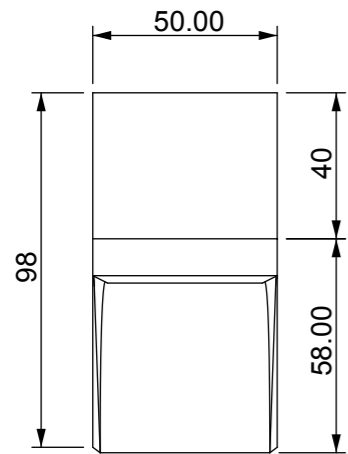
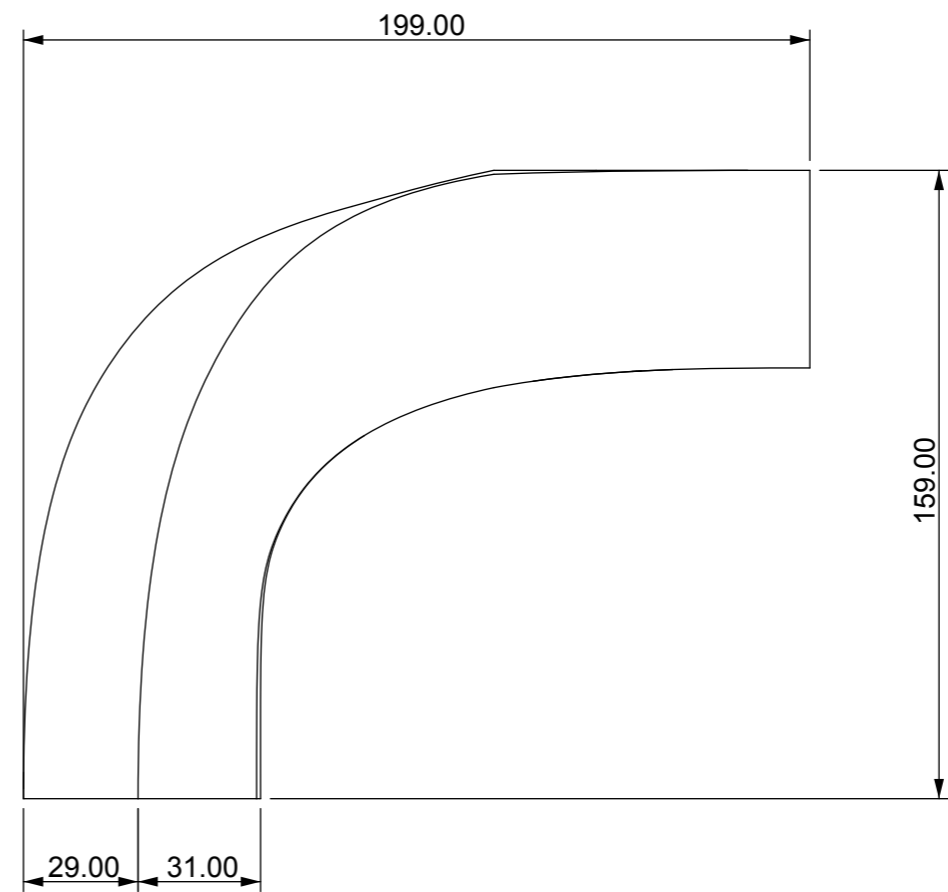
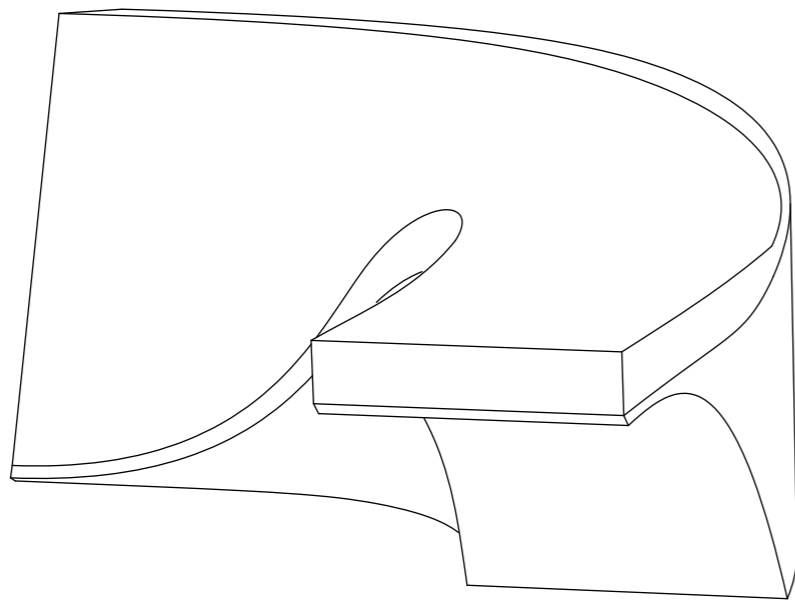
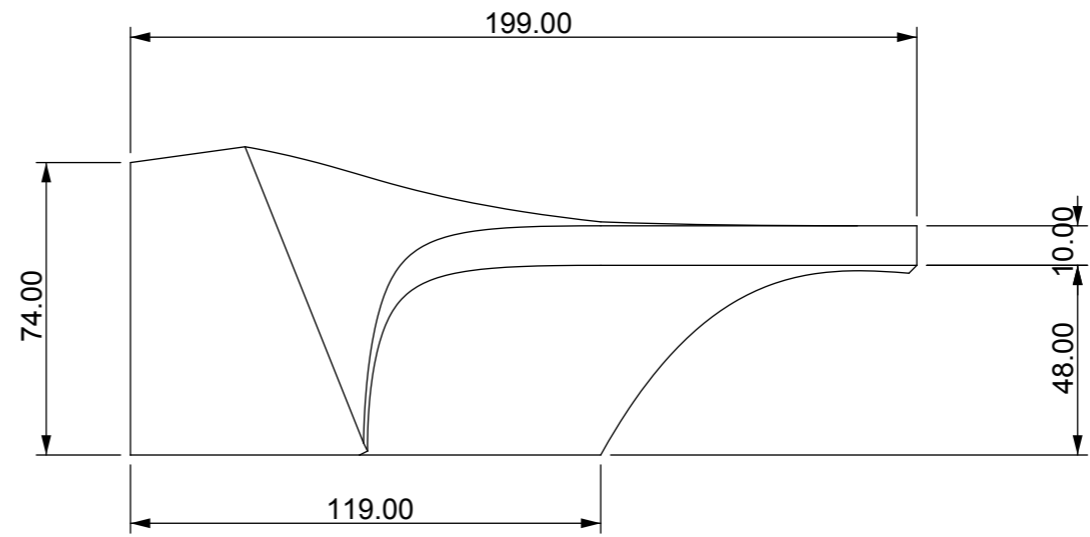
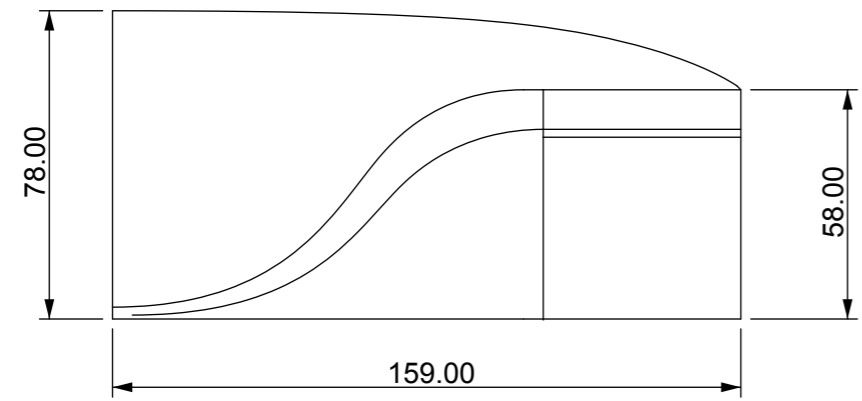
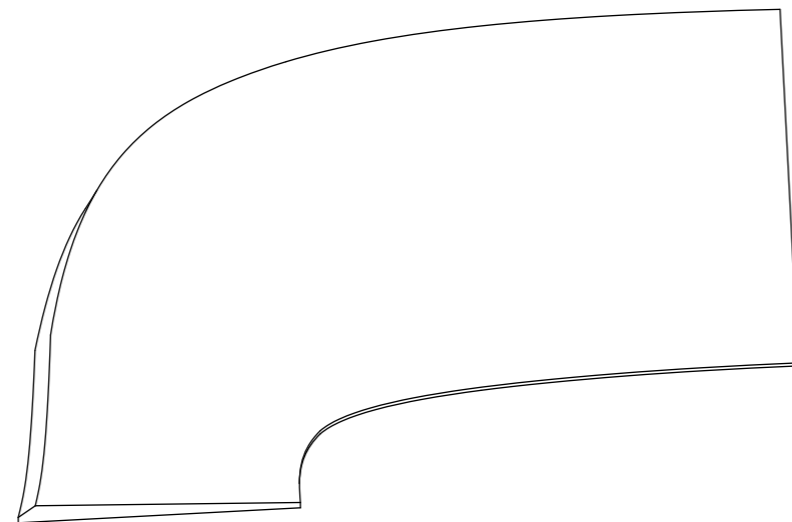
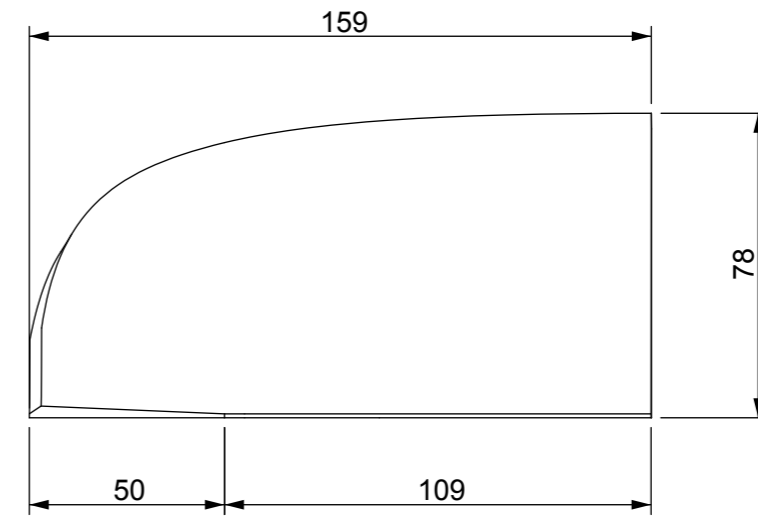
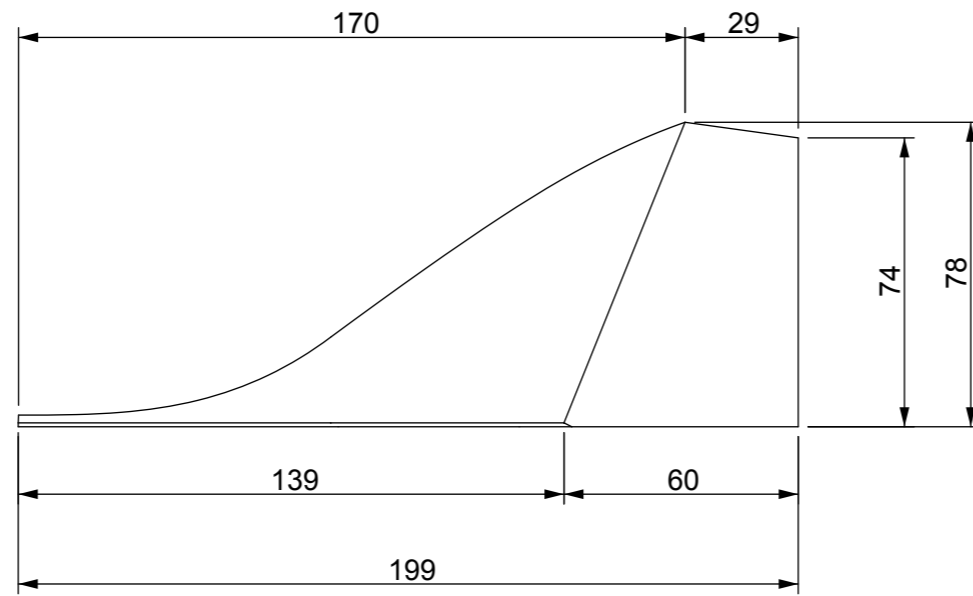
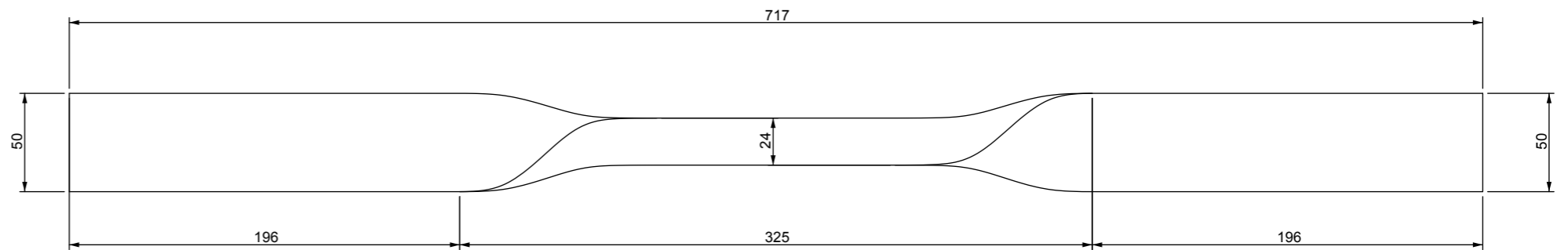
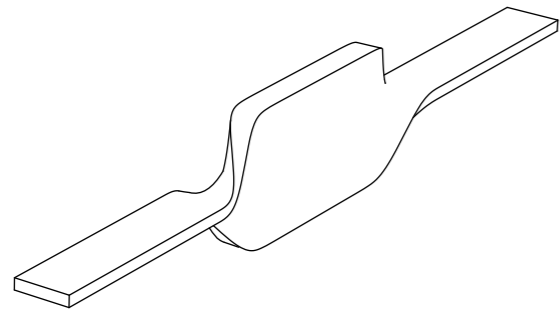
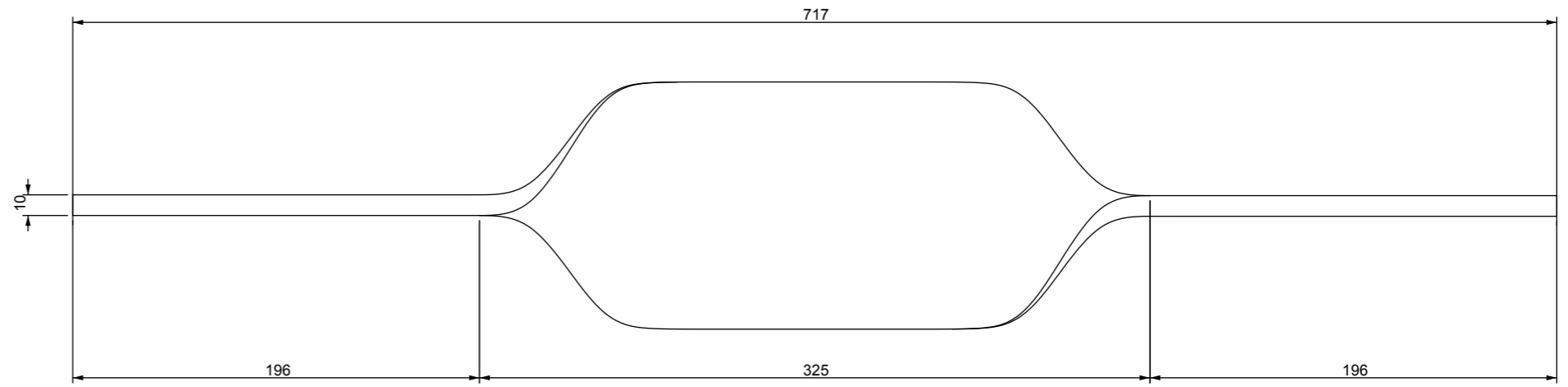
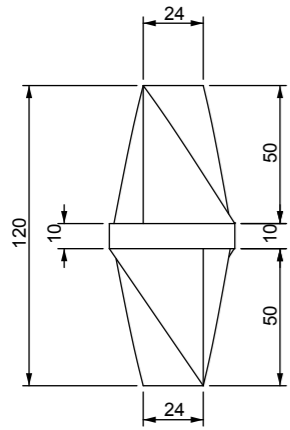

5/8

OBJETO:
MÓDULO DE ACCIÓN N°4 MA4

CONTENIDO:
DIMENSIONES GENERALES

ESCALA:
SIN ESCALA

FORMATO:
A3

DIMENSIONES:
CENTÍMETROS

PROYECTO:
SOPORTE RECREATIVO PARA LA PRÁCTICA DE DEPORTES EXTREMOS URBANOS DE DELIZAMIENTO

DIBUJO:
KENNETH ESPINOZA AGAS

